

The Siemens logo is displayed in a bold, teal, sans-serif font.

Ingenuity for life

Cerberus[®] PRO Compact

Combining innovation & intelligibility in a flexible, cost-effective system

usa.siemens.com/cerberus-pro

The Cerberus PRO 252/504 pt Panel, otherwise known as Cerberus PRO Compact, is an intelligent fire alarm control panel that is scalable to meet customers' evolving needs and customizable, allowing you to build the most cost effective system for any mid-to-large facility.

Protect your investment in your existing systems, as the FC922/924 and FV922/924 is backwards compatible with Siemens legacy systems and devices. This provides the ability to retain all field devices as you update your control panel.

Flexible System Design

Cerberus PRO Compact is a versatile, flexible and efficient system including:

- See all fire and non-fire emergency events on a single display
- Control a network of systems as though it were all a local panel
- Enjoy the flexibility of communicating everyday and emergency messages
- A broad range of detectors with more than 20 selectable detection profiles offer coverage for all types of application areas, from clean to dirty environments. Detectors featuring unique ASAtechnology™ offer reliable detection without false alarms.
- Remote viewing and evaluation of the system increases service efficiency and minimizes on-site maintenance time, which helps save time and money. With remote diagnostics, service visits can be planned more effectively, as the service engineer will know which parts are needed before visiting the site.
- Custom system design lets you easily distribute detectors and modules across the building.
- PAD-5 power supply with expanded flexibility in designing multi-floor systems and features like isolation device capability and Siemens patented Boost Technology.
- Mixed functionality loops let you mix and match detectors and modules on circuits.
- Fully compatible with Cerberus PRO advanced, standard, and H-series devices, as well as Class X/DCLC (isolation), Class A and Class B circuits.

Key Benefits

- Both fire and voice communication in one integrated system
- Networkable 252 and 504 pt panels
- Network connection via CAT5 or Fiber
- UL/ULC Listed for fire (UL864 & S527) and mass notification (UL2572 & S576) in one panel
- IP Voice technology offers industry leading communication, speed, and intelligibility
- Digital voice technology – the industry's best intelligibility – communicates 300 clear messages
- Remote serviceability utilizing the latest cloud technology for a faster and more cost-effective response
- Cloud/remote connectivity using Siemens products provides greater serviceability options, cost efficiencies, and faster response times
- Approved for use in releasing applications

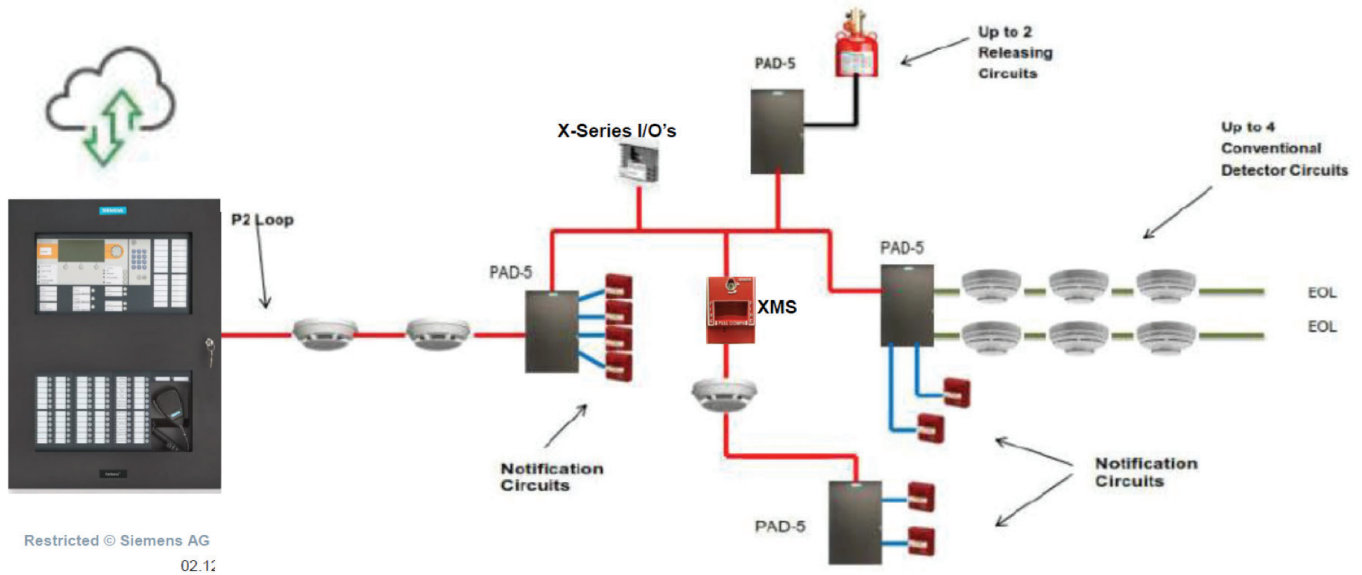

Industry-leading Detection

Siemens family of detectors and fire panels provide the innovative features and digital intelligence for the most reliable fire alarm system available.

- **Distributed digital intelligence:** Siemens detection devices provide decision making and storage of critical data at the device itself, improving reliability and speed of communication.
- **Full range of detection options:** compatibility with a wide variety of detection options allows the protection of environments, from sensitive to harsh, to be protected with equal reliability.
- The industry's only **No-False Alarm Guarantee** offers the earliest possible warning of a fire without the risk of false alarms.

Applications

The Compact system is suitable for a variety of mid-size to large facilities, such as:

- Marine
- K-12 Schools
- Mixed Use Buildings
- Hospitality (Hotel/ Motel)
- Low & Mid Rise Office Buildings

Coast Guard Approvals

The Cerberus® PRO Compact fire systems have been granted an Exceptional Degree of Protection by the United States Coast Guard. This updated approval expands the opportunities in the marine and harsh environment markets. The additional approval allows the use of the Siemens equipment in locations exposed to weather, seas, splashing, pressure-directed liquids, or similar moisture conditions.



Cerberus PRO

Cerberus PRO is the complete dedicated portfolio for Siemens Solution Partners in the UL/ULC Fire and Life Safety market. Cerberus PRO is a comprehensive portfolio of fire panels, detection and management stations which meet the needs of small-to-large or simple-to-complex applications.

Siemens Industry, Inc.

8 Fernwood Road
 Florham Park, NJ 07932, USA
 Tel (973) 593-2600
 Fax (973) 593-6670

All rights reserved. Printed in USA
 Part # 153-SBT-563
 ©2020 Siemens Industry, Inc.
 All trademarks are property of their respective owners.

Contact customer service to find the right Solution Partner in your region!

To start your next fire & life safety project, and learn about which solution is best for your needs, contact Siemens Customer Service today. Call us at (800) 262-7976, or email inquiries to fpkcustomerservice.industry@siemens.com.